

A35

398SAE008EN00

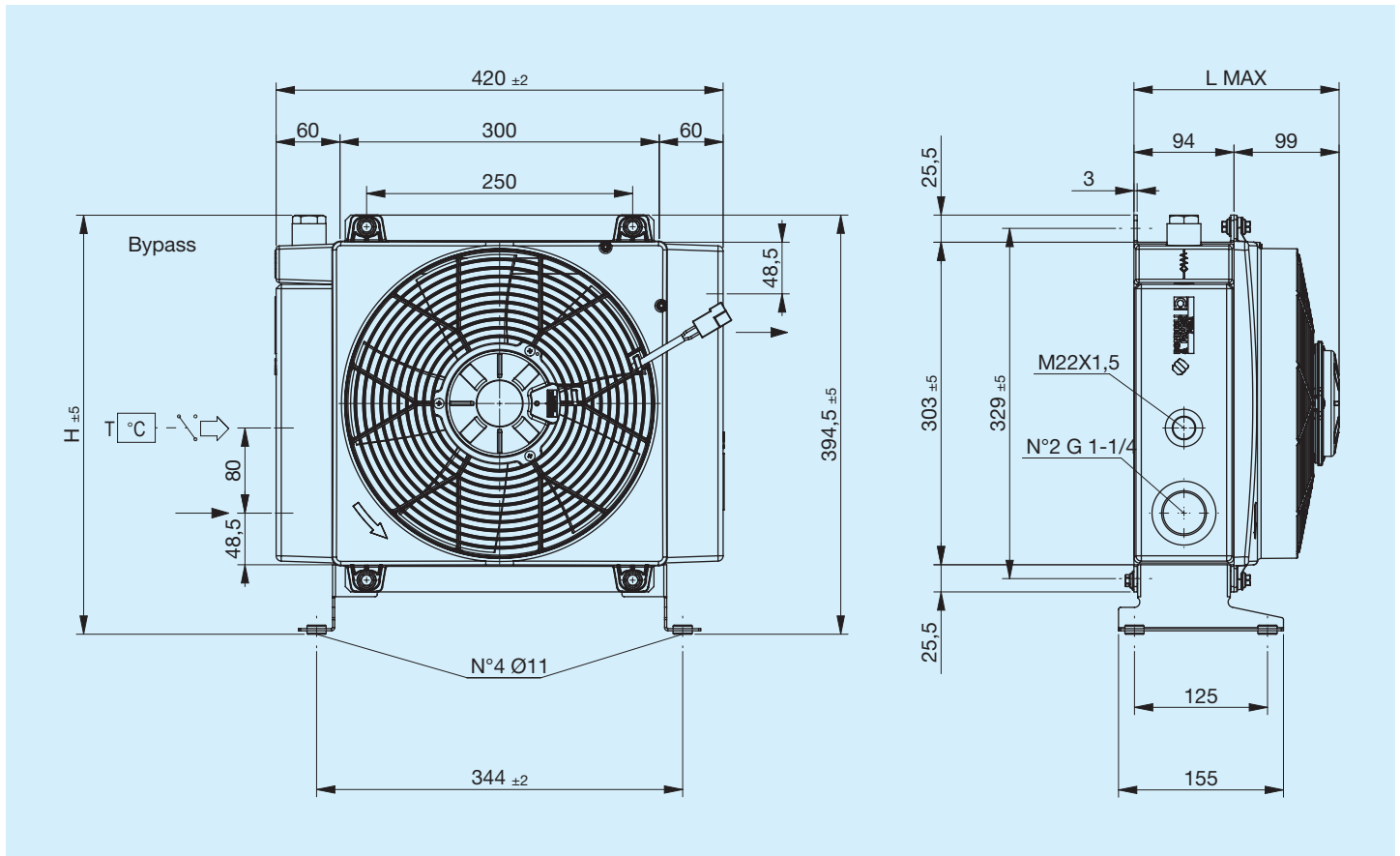

Before using the heat exchanger, carefully read the document entitled GENERAL INSTRUCTIONS FOR HEAT EXCHANGER USE.



Code	Description	Ø Fan mm	Air flow m ³ /h	Voltage V	Amperage A	L Max mm	H mm	Weight Kg	Capacity l
FR633063105	A35 1EAX 12V bypass T15 V.T. 3 bar 60°C	280	2350	12	15	230	394	15,5	4,8
FR633063106	A35 1ESX 12V bypass T15 V.T. 3 bar 60°C	280	2350	12	15	230	394	15,5	4,8
FR633061005	A35 1EAX 12V bypass T15 VNR 4.5 bar	280	2350	12	15	230	378	15,5	4,8
FR633061006	A35 1ESX 12V bypass T15 VNR 4.5 bar	280	2350	12	15	230	378	15,5	4,8
FR633063115	A35 1EAX 24V bypass T15 V.T. 3 bar 60°C	280	2500	24	7	230	394	15,5	4,8
FR633063116	A35 1ESX 24V bypass T15 V.T. 3 bar 60°C	280	2500	24	7	230	394	15,5	4,8
FR633061015	A35 1EAX 24V bypass T15 VNR 4.5 bar	280	2500	24	7	230	378	15,5	4,8
FR633061016	A35 1ESX 24V bypass T15 VNR 4.5 bar	280	2500	24	7	230	378	15,5	4,8
FR633060003	A35 1EAP 12V	280	1420	12	9	210	395	14,5	4,8
FR633060004	A35 1ESP 12V	280	1420	12	9	210	395	14,5	4,8
FR633060005	A35 1EAX 12V	280	2350	12	15	230	395	15,5	4,8
FR633060006	A35 1ESX 12V	280	2350	12	15	230	395	15,5	4,8
FR633060013	A35 1EAP 24V	280	1550	24	5	210	395	14,5	4,8
FR633060014	A35 1ESP 24V	280	1550	24	5	210	395	14,5	4,8
FR633060015	A35 1EAX 24V	280	2500	24	7	230	395	15,5	4,8
FR633060016	A35 1ESX 24V	280	2500	24	7	230	395	15,5	4,8

Heat exchange capacity

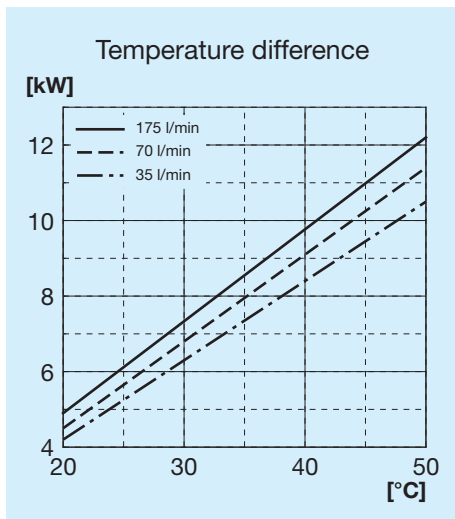

Radiator passage pressure drop

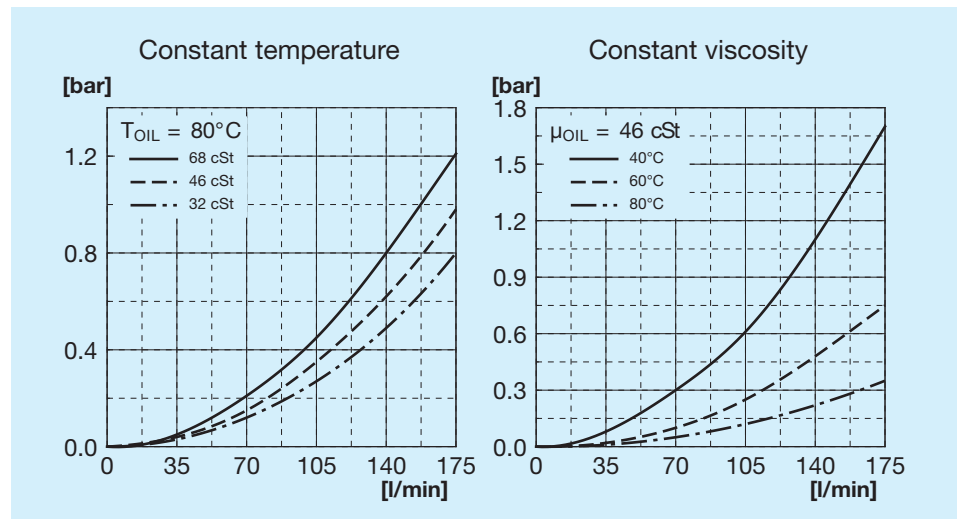

Bypass passage load loss

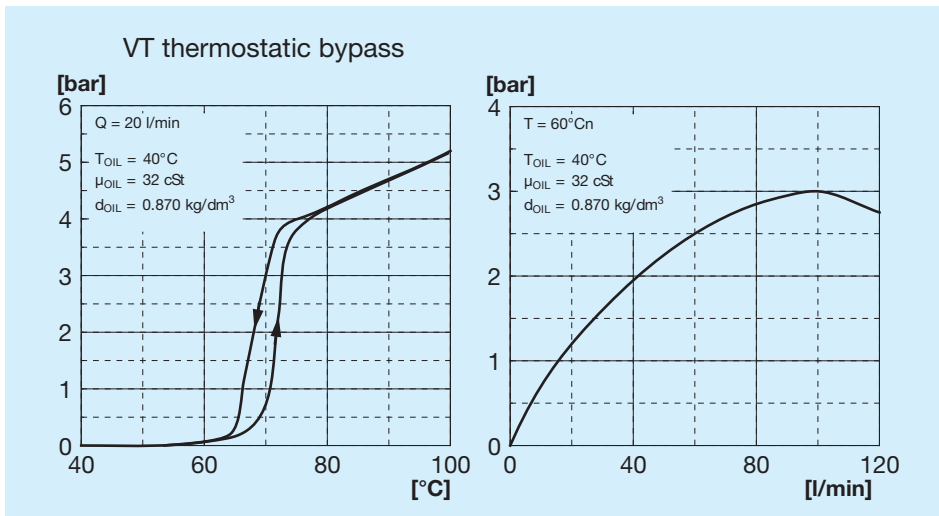

Bypass valves

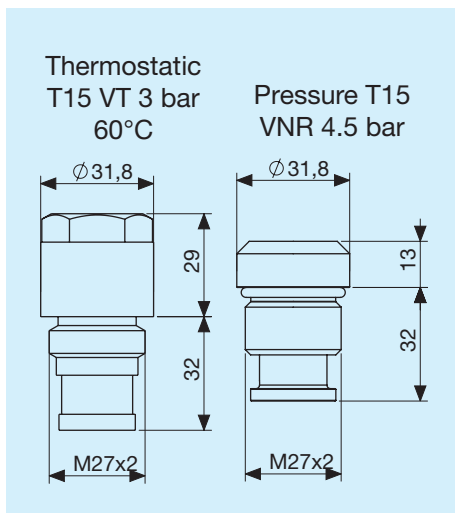

Legend

A22	Exchanger type
1E	1 Fan unit
AP	High power aspirating
SP	High power blower
AX	Extra high power aspirating
SX	Extra high power blower
12V	Fan unit voltage
24V	Fan unit voltage
T15 VT	Thermostatic bypass valve 3 bar 60°C
T15 VNR	Pressure bypass valve at 4.5 bar

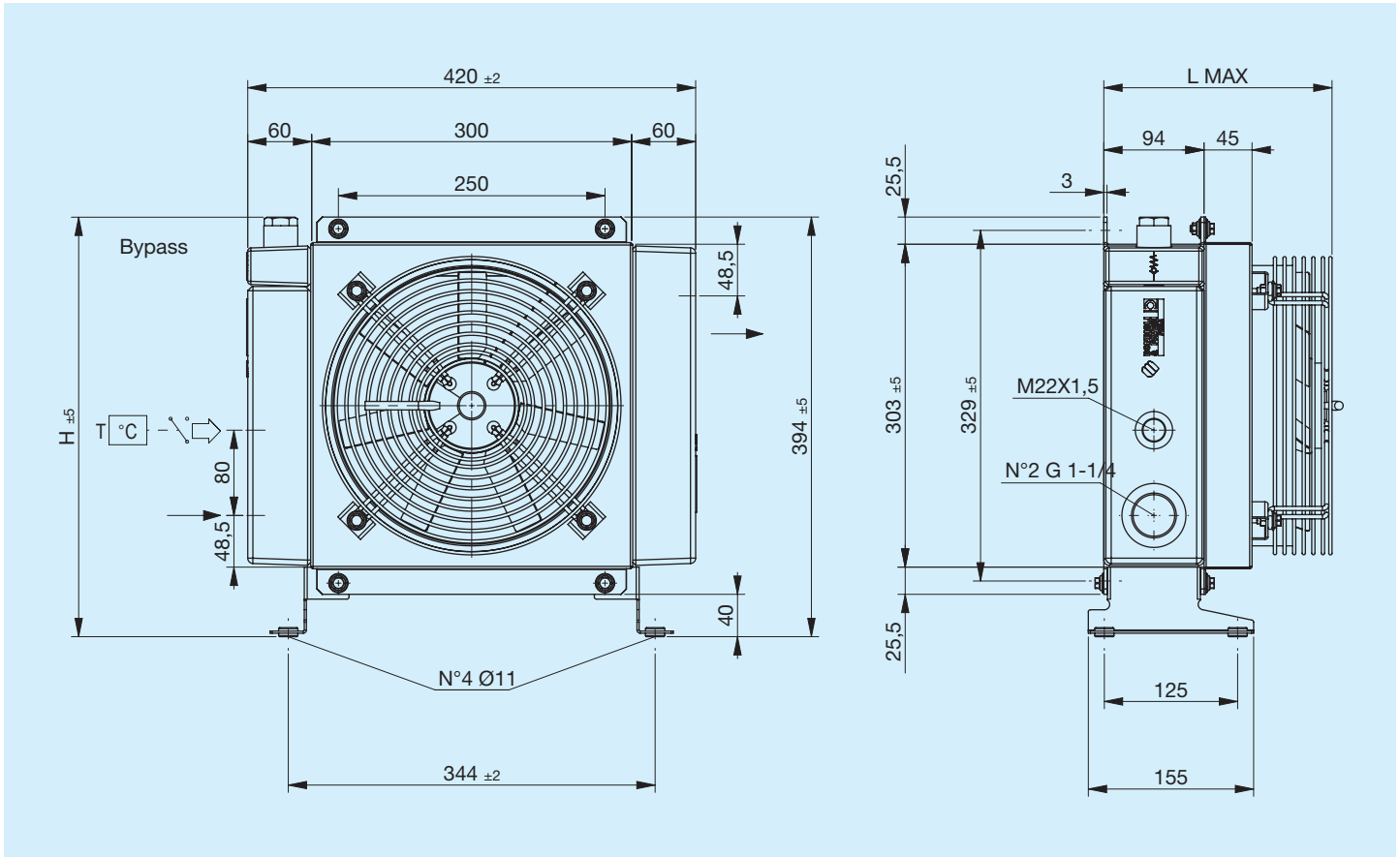

Code	Description	Ø Fan	Power	Frequency	Velocity	IP	L Max	H	Weight	Capacity
		mm	W	Hz	min ⁻¹		mm	mm		
FR633063131	A35 1EA 230V bypass T15 V.T. 3 bar 60°C	250	160	50 60	2500 2600	44	214	394	13,2	4,8
FR633063132	A35 1ES 230V bypass T15 V.T. 3 bar 60°C	250	160	50 60	2500 2600	44	214	394	13,2	4,8
FR633061031	A35 1EA 230V bypass T15 VNR 4.5 bar	250	160	50 60	2500 2600	44	214	378	13,2	4,8
FR633061032	A35 1ES 230V bypass T15 VNR 4.5 bar	250	160	50 60	2500 2600	44	214	378	13,2	4,8
FR633063121	A35 1EA 400V bypass T15 V.T. 3 bar 60°C	250	160	50 60	2450 2550	44	214	394	13,2	4,8
FR633063122	A35 1ES 400V bypass T15 V.T. 3 bar 60°C	250	160	50 60	2450 2550	44	214	394	13,2	4,8
FR633061021	A35 1EA 400V bypass T15 VNR 4.5 bar	250	160	50 60	2450 2550	44	214	378	13,2	4,8
FR633061022	A35 1ES 400V bypass T15 VNR 4.5 bar	250	160	50 60	2450 2550	44	214	378	13,2	4,8
FR633060031	A35 1EA 230V	250	160	50 60	2500 2600	44	214	395	13,2	4,8
FR633060032	A35 1ES 230V	250	160	50 60	2500 2600	44	214	395	13,2	4,8
FR633060021	A35 1EA 400V	250	160	50 60	2450 2550	44	214	395	13,2	4,8
FR633060022	A35 1ES 400V	250	160	50 60	2450 2550	44	214	395	13,2	4,8

Heat exchange capacity

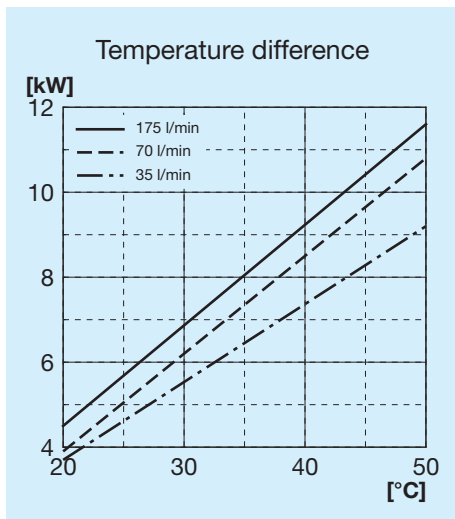

Radiator passage pressure drop

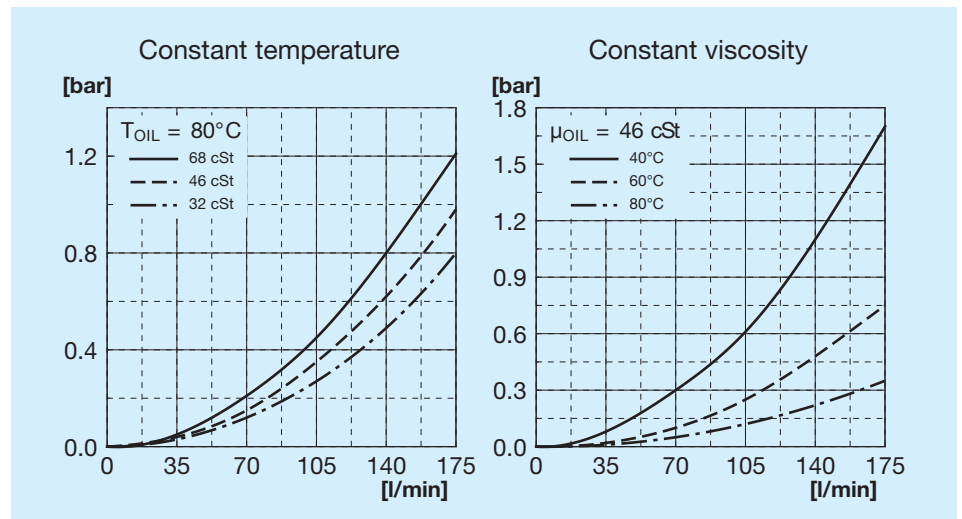

Bypass passage load loss

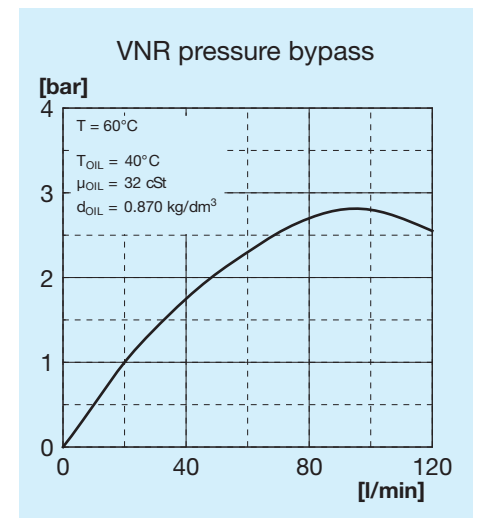
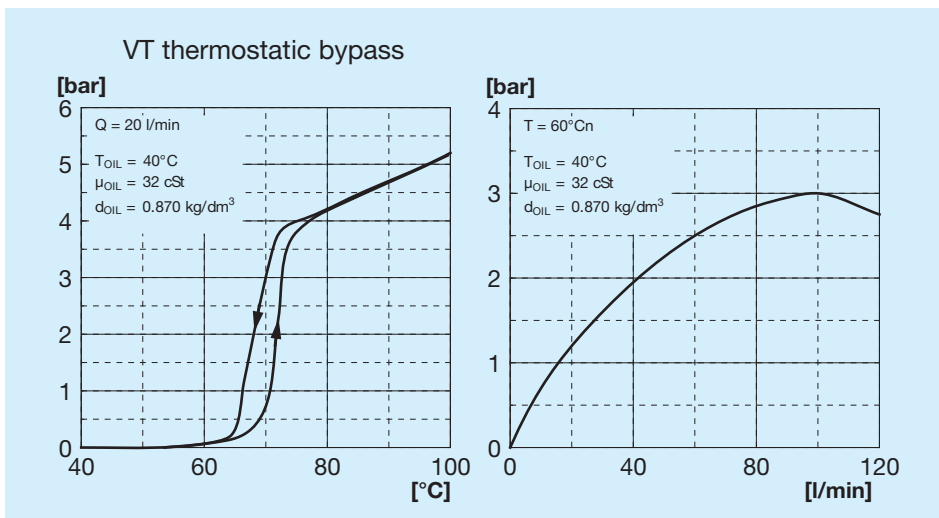

Bypass valves

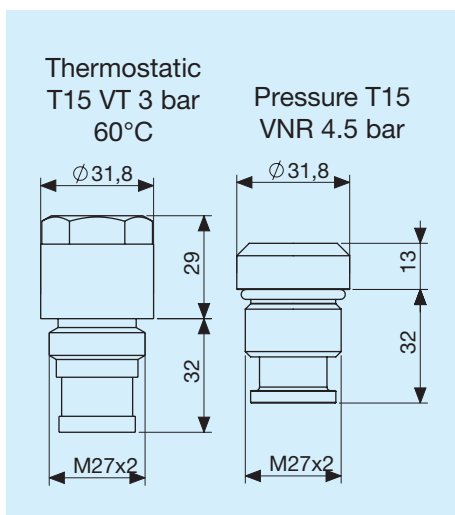

Legend

A22	Exchanger type
1E	1 Fan unit
AP	High power aspirating
SP	High power blower
AX	Extra high power aspirating
SX	Extra high power blower
12V	Fan unit voltage
24V	Fan unit voltage
T15 VT	Thermostatic bypass valve 3 bar 60°C
T15 VNR	Pressure bypass valve at 4.5 bar

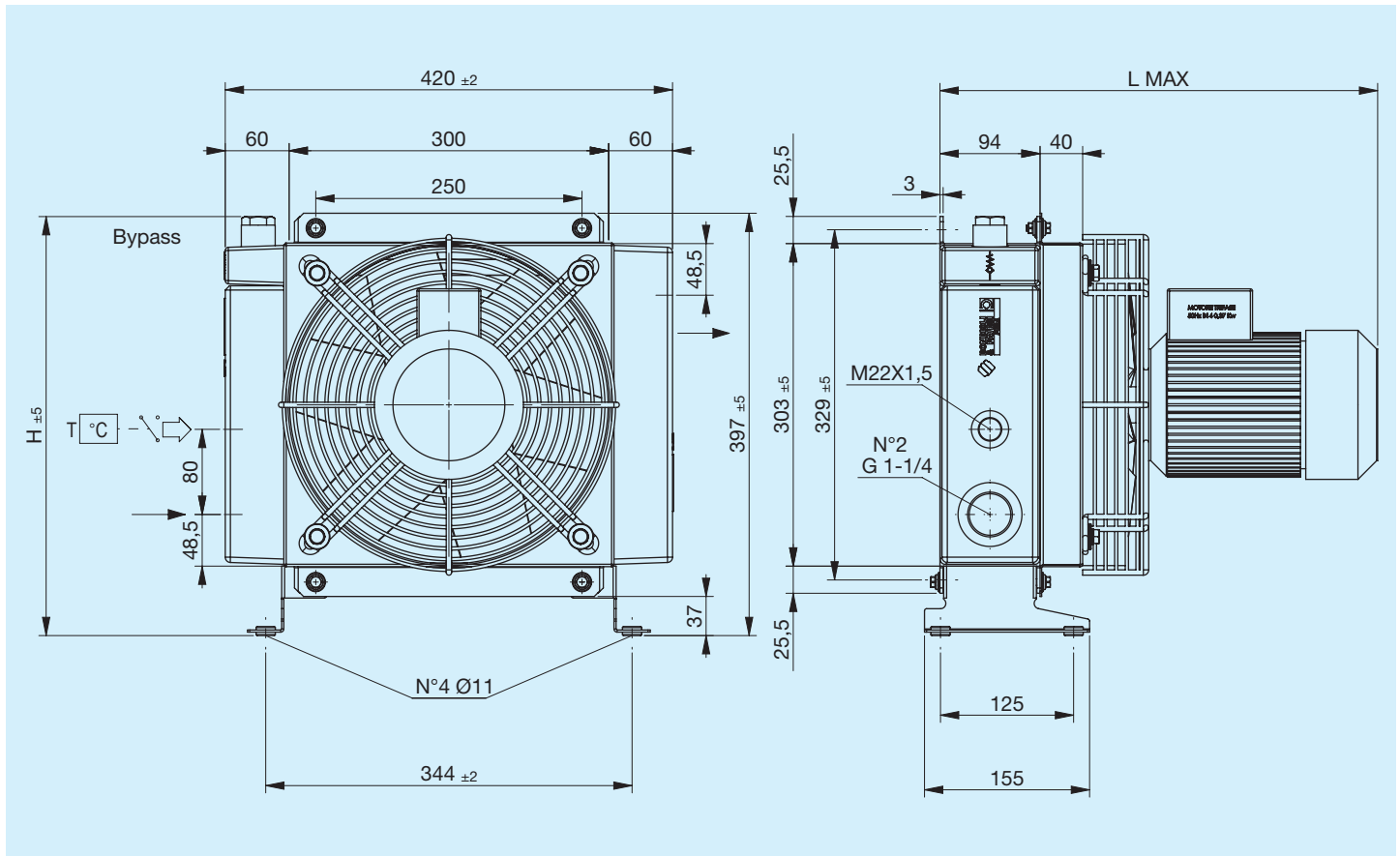

Code	Description	Ø Fan	Power	Frequency	Velocity	IP	L Max	H	Weight	Capacity
		mm	W	Hz	min ⁻¹	Rating	mm	mm	Kg	l
FR633063141	A35 1EA 220V-B14 bypass T15 V.T. 3 bar 60°C	290	370	50	2790	65	411	394	18	4,8
FR633063142	A35 1EA 220V-B14 bypass T15 V.T. 3 bar 60°C	290	370	50	2790	65	411	394	18	4,8
FR633061041	A35 1EA 220V-B14 bypass T15 VNR 4.5 bar	290	370	50	2790	65	411	378	18	4,8
FR633061042	A35 1EA 220V-B14 bypass T15 VNR 4.5 bar	290	370	50	2790	65	411	378	18	4,8
FR633063151	A35 1EA 380V-B14 bypass T15 V.T. 3 bar 60°C	290	370	50	2790	65	411	394	18	4,8
FR633063152	A35 1ES 380V-B14 bypass T15 V.T. 3 bar 60°C	290	370	50	2790	65	411	394	18	4,8
FR633061051	A35 1EA 380V-B14 bypass T15 VNR 4.5 bar	290	370	50	2790	65	411	378	18	4,8
FR633061052	A35 1ES 380V-B14 bypass T15 VNR 4.5 bar	290	370	50	2790	65	411	378	18	4,8
FR633060041	A35 1EA 220V-B14	290	370	50	2790	65	411	395	18	4,8
FR633060042	A35 1ES 220V-B14	290	370	50	2790	65	411	395	18	4,8
FR633060051	A35 1EA 380V-B14	290	370	50	2790	65	411	395	18	4,8
FR633060052	A35 1ES 380V-B14	290	370	50	2790	65	411	395	18	4,8

Heat exchange capacity

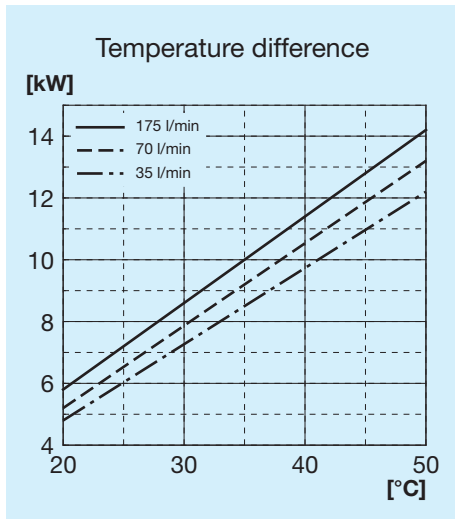

Radiator passage pressure drop

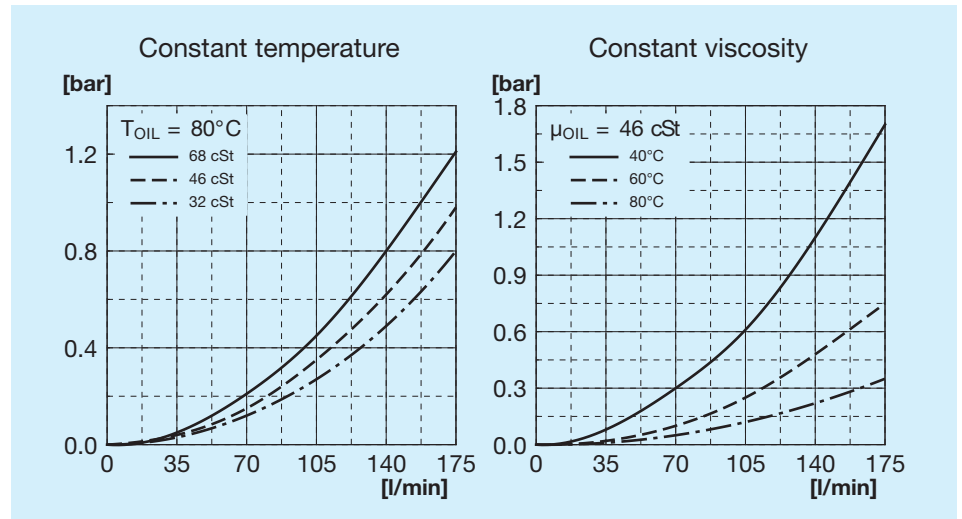

Bypass passage load loss

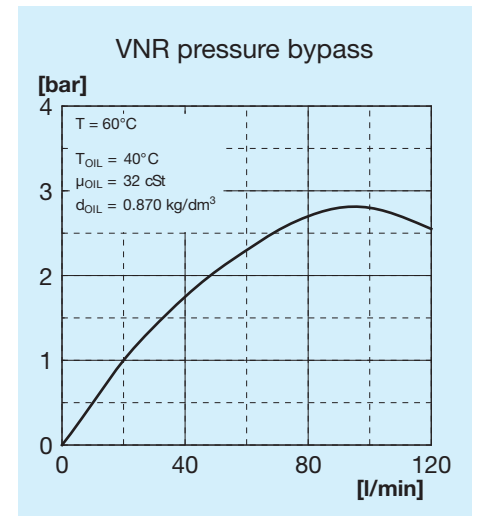
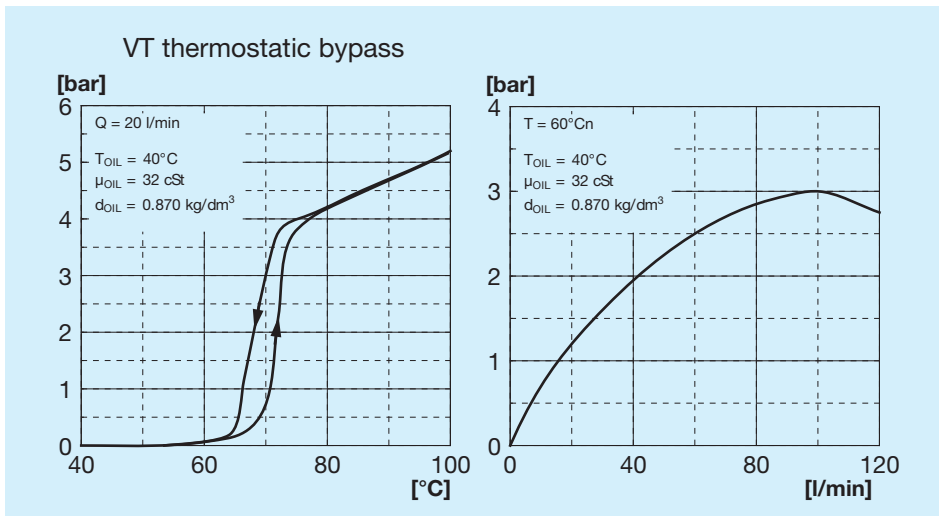

Bypass valves

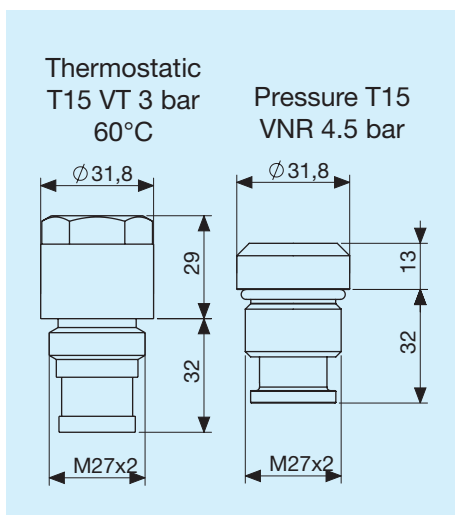

Legend

A22	Exchanger type
1E	1 Fan unit
AP	High power aspirating
SP	High power blower
AX	Extra high power aspirating
SX	Extra high power blower
12V	Fan unit voltage
24V	Fan unit voltage
T15 VT	Thermostatic bypass valve 3 bar 60°C
T15 VNR	Pressure bypass valve at 4.5 bar

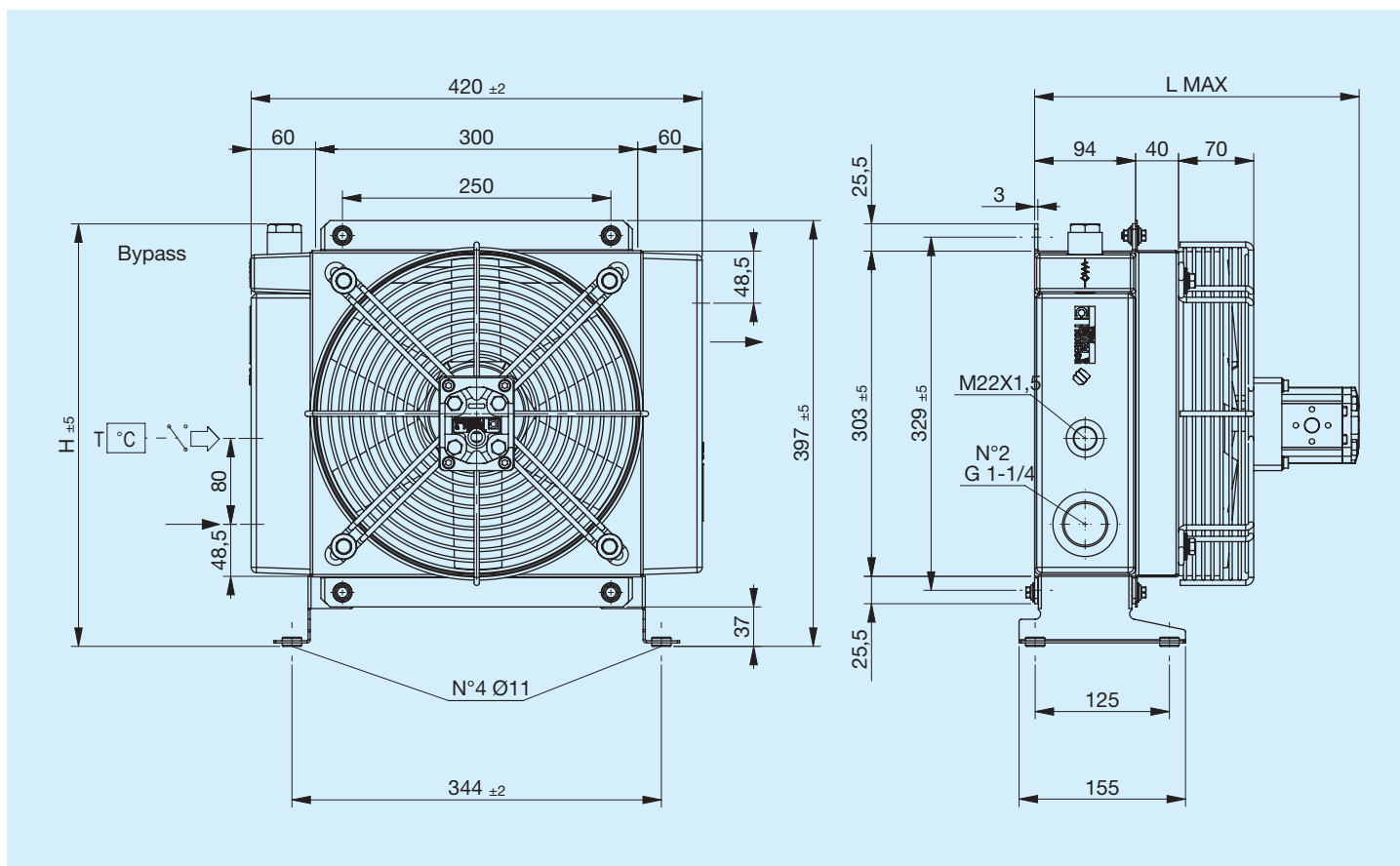

Code	Description	Ø Fan mm	Displacement motors cm ³ /h	L Max mm	H mm	Weight Kg	Capacity l
FR634063113	A35 IA MOT. IDR. GR1 bypass T15 V.T. 3 bar 60°C	290	6	305	394	18	4,8
FR634063114	A35 IS MOT. IDR. GR1 bypass T15 V.T. 3 bar 60°C	290	6	305	394	18	4,8
FR634061013	A35 IA MOT. IDR. GR1 bypass T15 VNR 4,5 bar	290	6	305	378	18	4,8
FR634061014	A35 IS MOT. IDR. GR1 bypass T15 VNR 4,5 bar	290	6	305	378	18	4,8
FR634060013	A35 IA MOT. IDR. GR1	290	6	305	395	18	4,8
FR634060014	A35 IS MOT. IDR. GR1	290	6	305	395	18	4,8

Heat exchange capacity

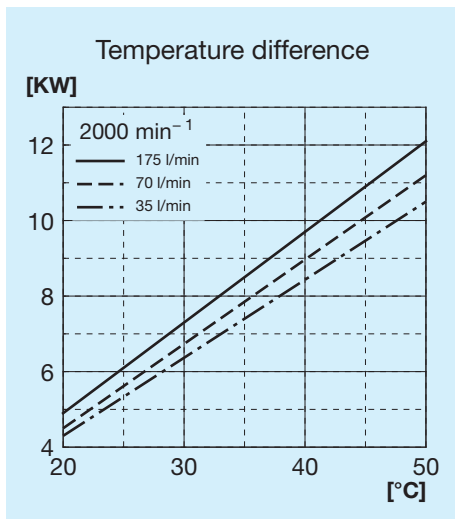

Radiator passage pressure drop

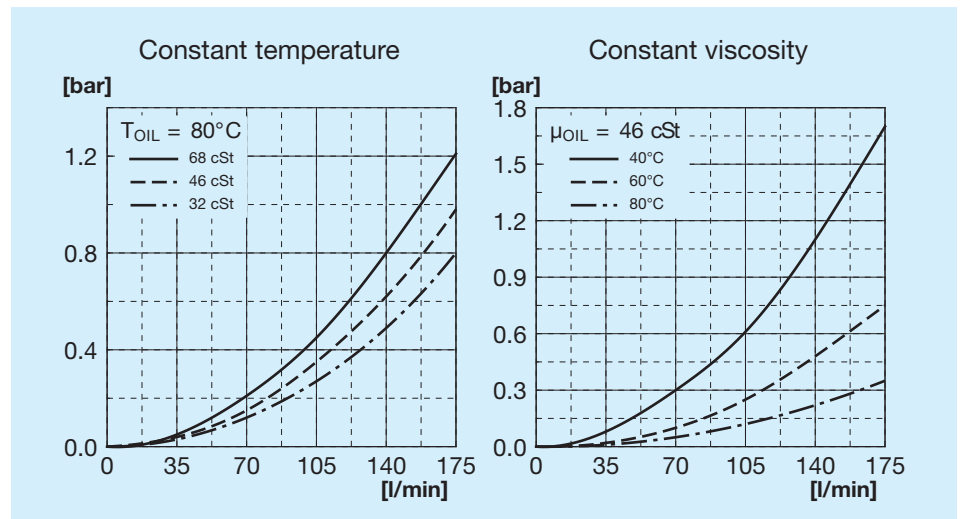

Bypass passage load loss

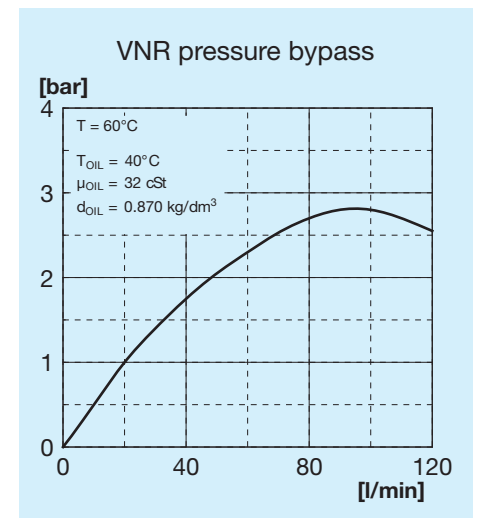
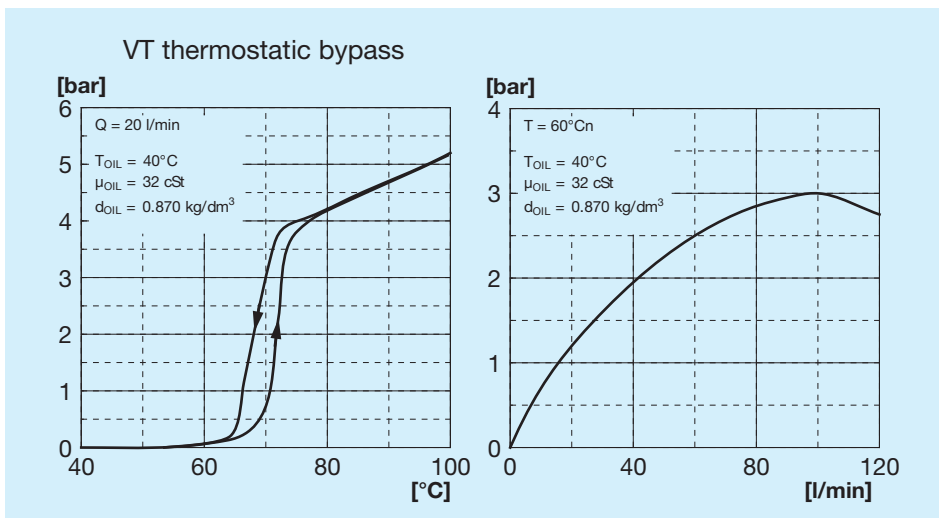

Bypass valves

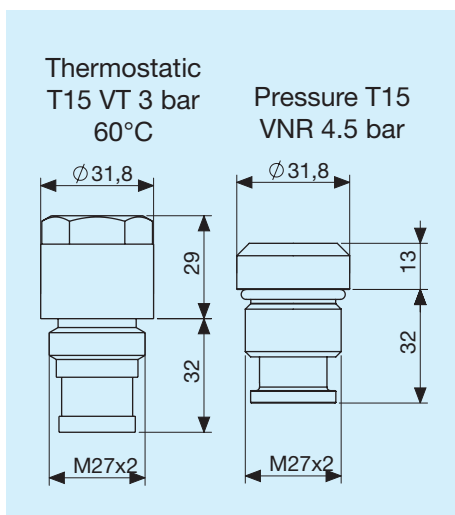

Legend

A22	Exchanger type
1E	1 Fan unit
AP	High power aspirating
SP	High power blower
AX	Extra high power aspirating
SX	Extra high power blower
12V	Fan unit voltage
24V	Fan unit voltage
T15 VT	Thermostatic bypass valve 3 bar 60°C
T15 VNR	Pressure bypass valve at 4.5 bar

Connector

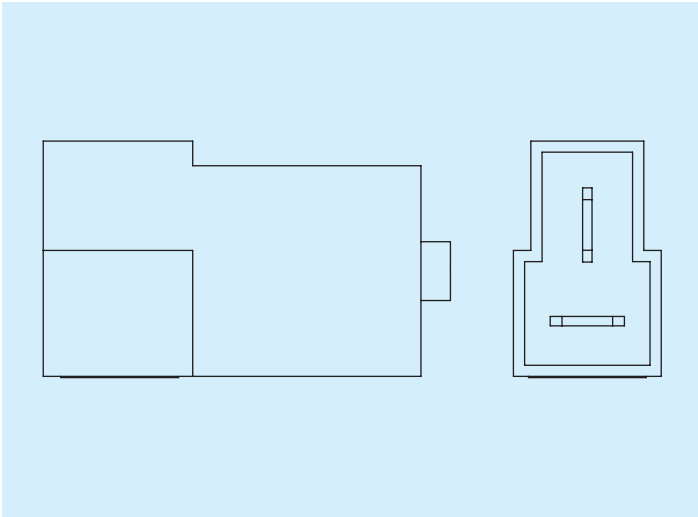

	Code
AMP connector	180908

Left supporting foot

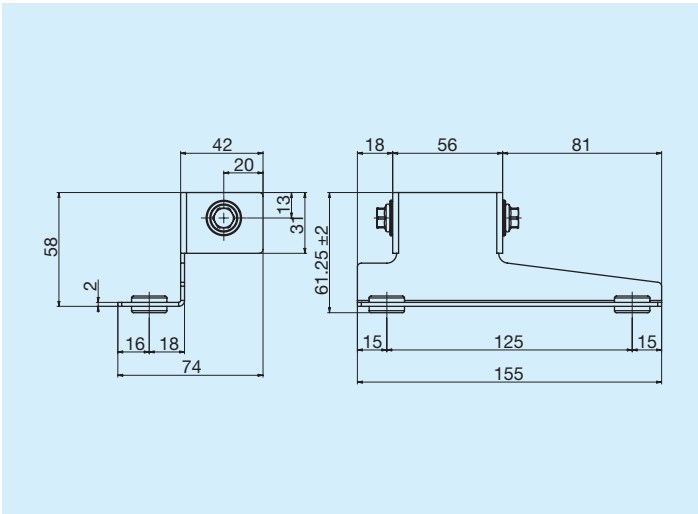

	Code
Left supporting foot	FR29000011

Right supporting foot

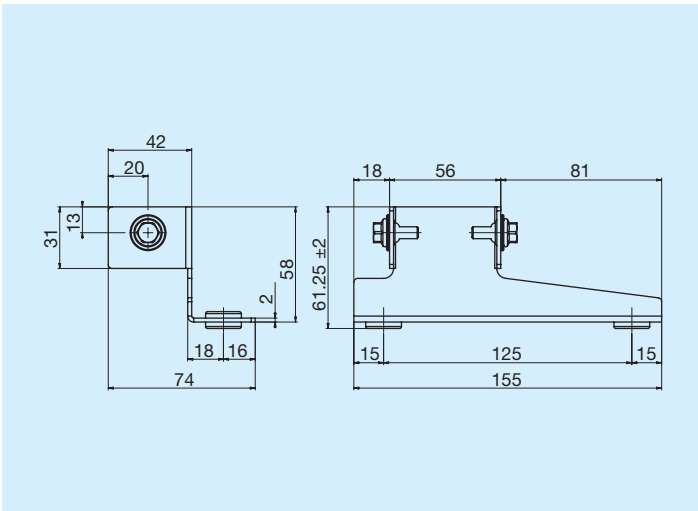

	Code
Right supporting foot	FR29000012

Thermostats

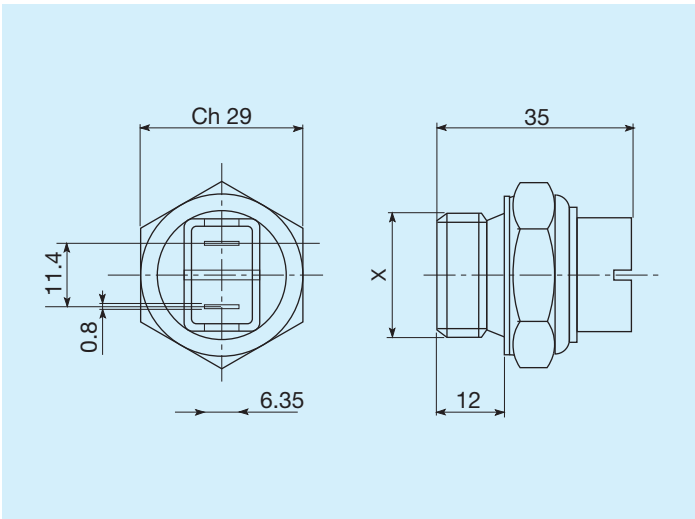

Trigger temperature °C		Code
45 - 35	M22x1.5	FR 361104535
60 - 50	M22x1.5	FR 361106050
80 - 70	M22x1.5	FR 361108070
82 - 68	M22x1.5	FR 361108268
85 - 76	M22x1.5	FR 361108576

IP54 protected thermal switch

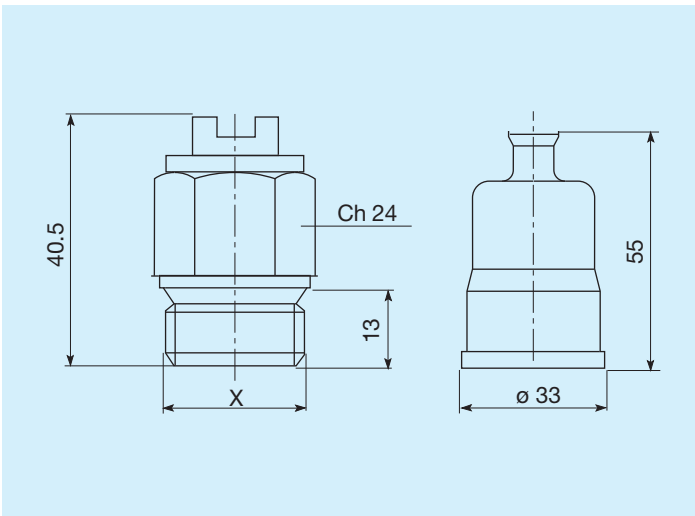

Trigger temperature °C		Code
45 - 35	M22x1.5	FR 361124535
50 - 40	M22x1.5	FR 361125040
60 - 50	M22x1.5	FR 361126050
70 - 60	M22x1.5	FR 361127060
80 - 70	M22x1.5	FR 361128070

IP65 protected thermal switch

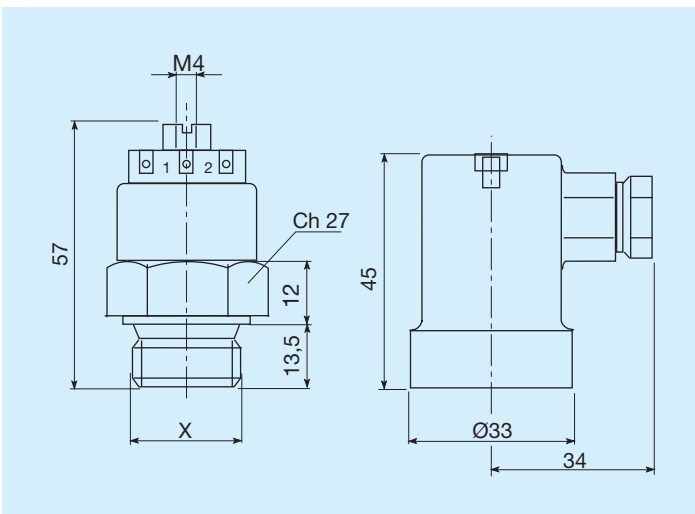

Trigger temperature °C		Code
45 - 35	M22x1.5	FR 361154535
47 - 36	M22x1.5	FR 361155040
60 - 50	M22x1.5	FR 361156050
80 - 70	M22x1.5	FR 361158070